

**Dimensions**

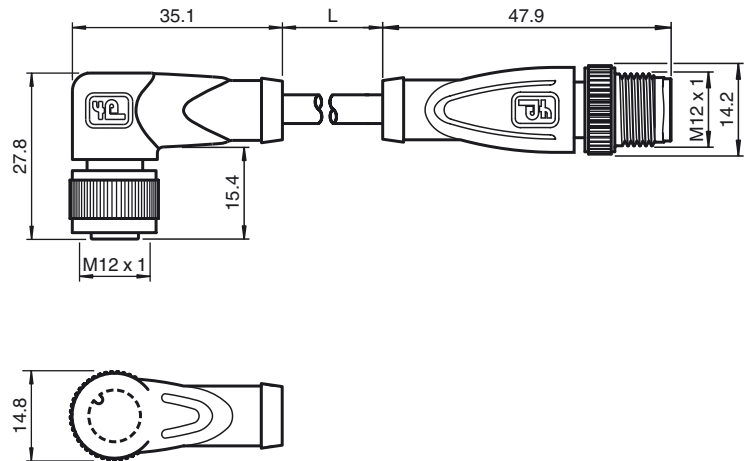

**Model Number**

**V11-W-15M-PUR-V11-G**

Connecting cable, M12 to M12, PUR cable 3-pin

**Features**

- Knurled nut suitable for tool assembly
- Immunity to vibration, with mechanical latching
- Gold-plated and machined contacts
- Degree of protection IP67 / IP68 / IP69K
- Halogen-free
- Suitable for 2- and 3-wire technology

**Technical data**

**General specifications**

Number of pins 3

**Electrical specifications**

Operating voltage  $U_B$  max. 300 V DC  
 Test voltage > 1500 V<sub>eff</sub> AC  
 Operating current  $I_B$  max. 4 A  
 Volume resistance < 5 mΩ

**Ambient conditions**

Ambient temperature -25 ... 100 °C (-13 ... 212 °F)  
 for temperatures over 80 °C (176 °F) reduced elongation at tear  
 Pollution degree 3

**Mechanical specifications**

Contact elements spring-loaded contact socket  
 Pin diameter 1 mm  
 Degree of protection IP67 / IP68 / IP69k  
 Material  
 Contacts CuSn / Au  
 Contact surface Au  
 Body TPU, green  
 Cable PUR  
 Slotted nut Diecast zinc  
 Sleeve connector Diecast zinc  
 Core insulation PP  
 Cable fine-strand, flexible  
 Sheath diameter Ø4.8 mm  
 Bending radius > 10 x cable diameter, moving  
 Color grey  
 Cores 3 x 0.34 mm<sup>2</sup>  
 Conductor construction 19 x 0.15 mm Ø  
 Length L 15 m  
 Flammability  
 Contact carrier 94 V-2  
 Housing 94 V-2

**Electrical connection**



Release date: 2016-04-05 15:08 Date of issue: 2016-04-05 21:4866\_eng.xml